

RMD-620

6 Channel Digital
Dimmer Pack



SYSTEM FEATURES

- 6 channel digital dimer pack
- 20A per channel (2400 watts)
- USITT DMX-512 (3PIN) input & output
- 2U 19" rack mount
- High speed micro processor
- Real time zero crossing detection
- Blue backlit digital display
- High quality chokes for minimal noise
- Individual or block channel patching
- Minimum channel output setting from 0-30%
- Maximum channel output setting from 70-100%
- Individual channel curve option setting
- Channel curve settings include Linear, Square, Non Dim and S-Curve.
- DMX fail backup feature- includes 12 internal chase programs, last scene hold and analog options
- Power failure memory
- Standard terminal type output panel- optional panels include: Edison, Socapex, Stage Pin- and Power Con
- DMX Output
- Analog Output
- Fan cooled
- 6 x 20A UL approved MCB breakers.
- Dimensions- 17" x 19" x 3.5"
- Weight- 21lbs.

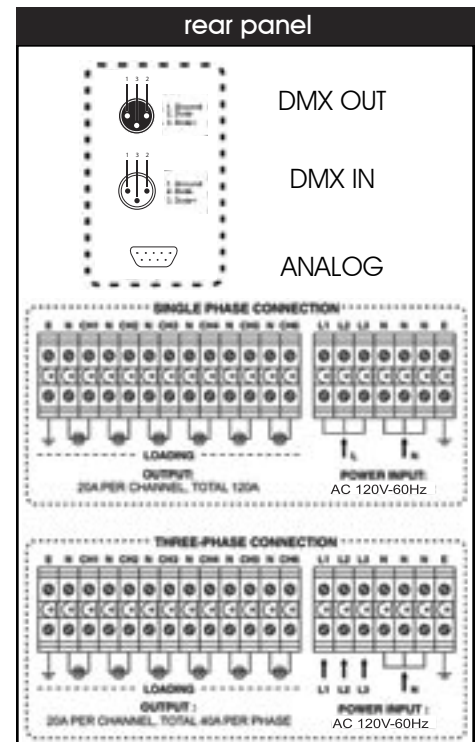

www.elationlighting.com

with **EVOLUTION**
comes **CHANGE**