



Tracpod 84

User Manual

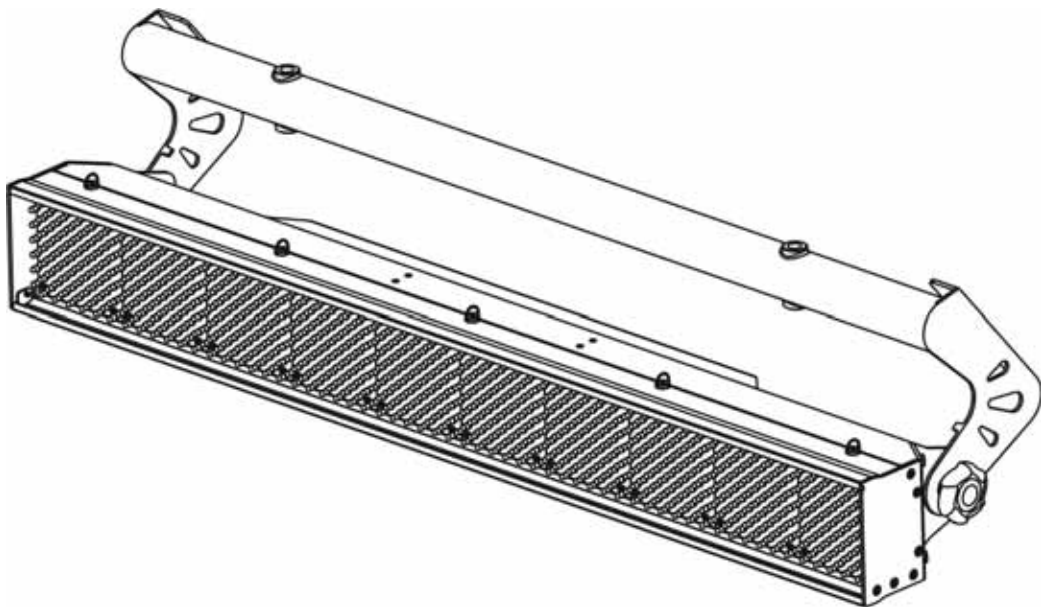

Table of Content

1. Introduction	
1.1 Features	2
1.2 Overview.....	3
1.3 Safety instructions	4
2. Installation	
2.1 Connection to mains.....	4
2.2 Connection between fixtures	5
2.3 Mounting the fixture	6
3. Operation	
3.1 Control menu map	8
3.2 DMX operation	8
3.3 Stand-alone operation	10
4. Technical Specification	12
5. Maintenance	13

Introduction

Thank you for purchasing Tracpod 84.

Tracpod 84 is a LED batten for professional use. With cutting-edge RGB color mixing technology capable to generate up to 16.5 million colors for use in stage production and fixed installation. The LED batten contains ten LED modules and each can separate into four individual sections, provides total of forty pixels capable to run graphics or matrix when multiple unit are used together. Tracpod 84 can be operated in stand-alone or advance control via external DMX controller.

WHAT IS INCLUDED

- 1 x Tracpod 84 LED batten
- 1 x Power cord
- 1 x Power connection cable
- User manual

Carefully unpack the carton, check the contents to ensure that all parts are present, and have been received in good condition. If any parts appear damaged or missing, notify the shipper immediately and retain packing material for inspection. In the event that the fixture must be returned to the factory, it is important that the fixture be returned in the original factory box and packing.

1.1 Features

- DMX 512.
- Standard 4 channels and full function 7 channels DMX control.
- Stand – alone operation:
 - Master/Slave.
 - Manual color mixing
 - Auto-chases with adjustable speed and fade.
 - 16 auto chases.
- 40 sections of LED module to create LED matrix effect.

1.2 Overview

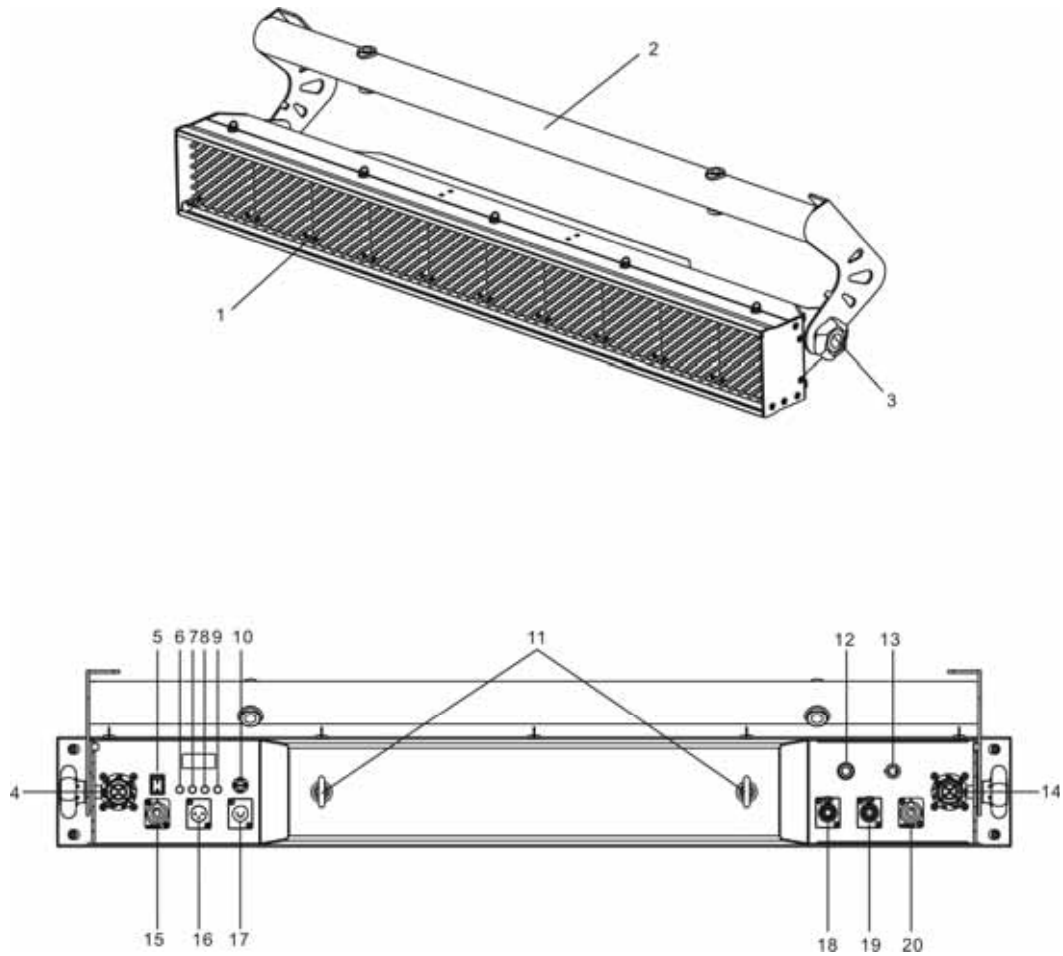

- | | |
|------------------|-----------------------|
| 1. LED Module | 11. Safety Ring |
| 2. Hanging Bar | 12. Microphone |
| 3. Gear Screw | 13. Sensitivity Level |
| 4. Fan | 14. Fan |
| 5. Power Switch | 15. Power Input |
| 6. Mode Button | 16. 3-PIN DMX Input |
| 7. Select Button | 17. 5-PIN DMX Input |
| 8. Up Button | 18. 5-PIN DMX Output |
| 9. Down Button | 19. 3-PIN DMX Output |
| 10. Fuse Holder | 20. Power Output |

1.3 Safety Instructions



CAUTION

UNPLUG MAINS BEFORE INSTALLING OR WIRING THE FIXTURE

User must be qualified to be involved with installation and maintenance of this product. User must follow the safety instruction and warning notes written in this manual.



CAUTION

NEVER LOOK DIRECTLY INTO THE LIGHT SOURCE

IMPORTANT

- For indoor use only
- Keep dry
- Install only in well ventilated areas
- Do not attempt to open the controller or fixture, no user serviceable parts inside.
- Before attaching the device, make sure the installation surface can hold a minimum point load of ten times the device's weight.

Installation

2.1 Connection to the mains

i. AC Power

Tracpod 84 is available in AC100-240V 50-60HZ and is supplied to match your local voltage and frequency.

ii. Replacing Plug

The power cable must be fitted with a grounding-type cord cap (earthed type mains plug) that fits your power distribution system.

Wire (EU)	Wire (US)	Pin	Marking
Brown	Black	Live	L
Blue	White	Neutral	N
Yellow	Green	GND	

2.2 Connection between fixtures

The fixture is equipped both 3 and 5-PIN XLR sockets for DMX input and output. Only use a shielded twisted pair cable designed for 3 or 5-PIN XLR plugs and connectors in order to connect the controller with fixture or one fixture with another.



i. DMX Serial Data Link

If you are using the standard DMX controller, you can connect the DMX output of the controller directly with the DMX input of the first fixture in the DMX-chain. Connect the DMX output of first fixture in the chain with DMX input of next fixture. Always connect one output with input of next fixture until all fixtures are connected.

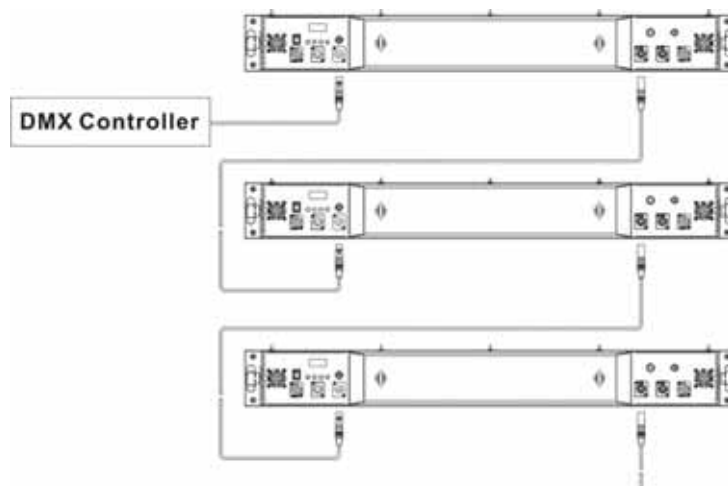

ii. Master/Slave Data Link

Connect the DMX output of the master fixture in the data chain with the DMX input of first slave fixture. Always connect output with the input of next slave fixture until all slave fixtures are connected.

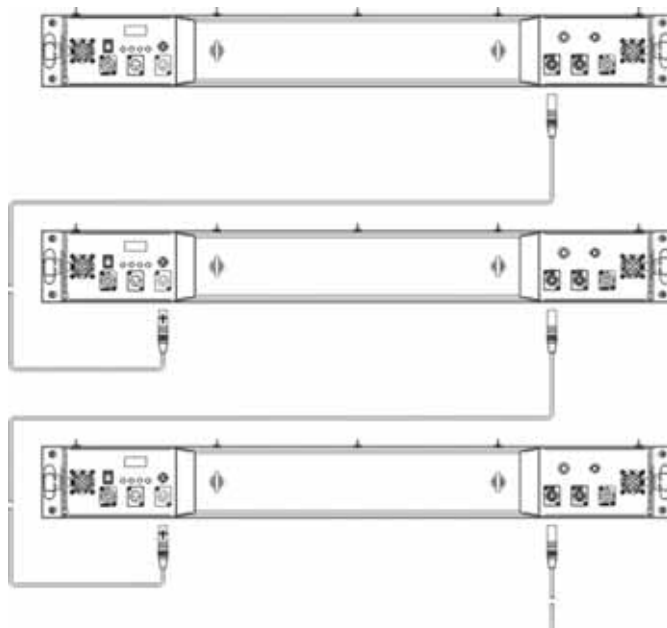

2.3 Mounting the fixture

i. Truss Mount

Fixture should be hung on truss structure using a mounting clamp. Always secure the fixture with a secondary safety attachment.

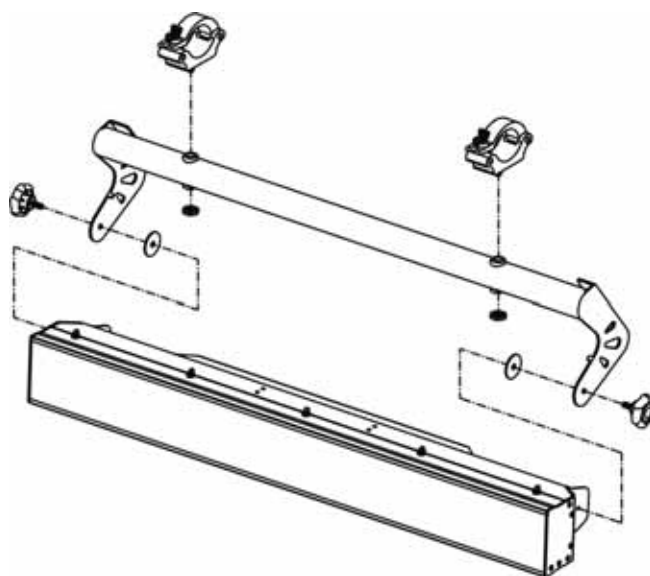

ii. Wall Mount

Mount the fixture to wall as illustrated below. Before attaching the device, make sure the installation surface can hold a minimum point load of 10 times the device's weight.

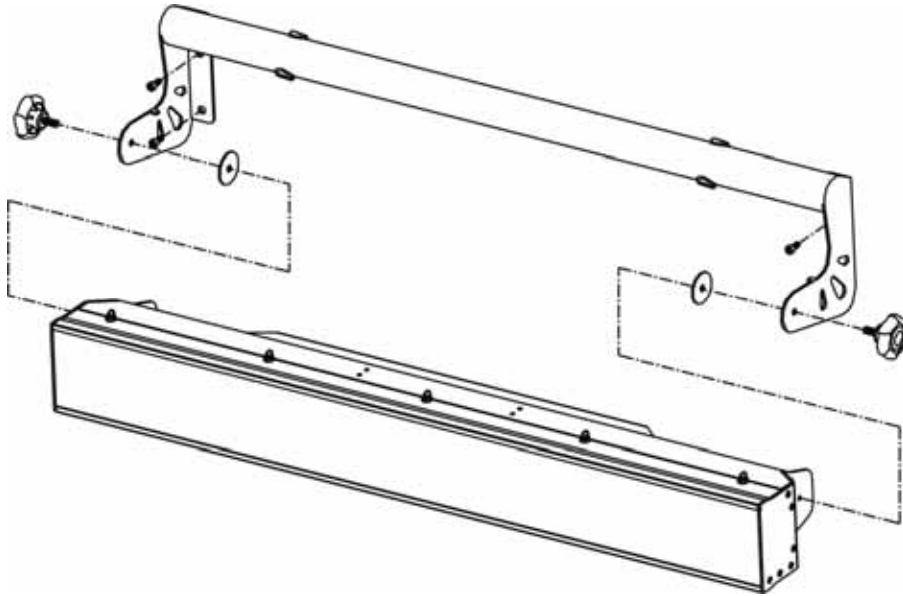

iii. Floor Mount

Mount the fixture on the ground floor as illustrated below.

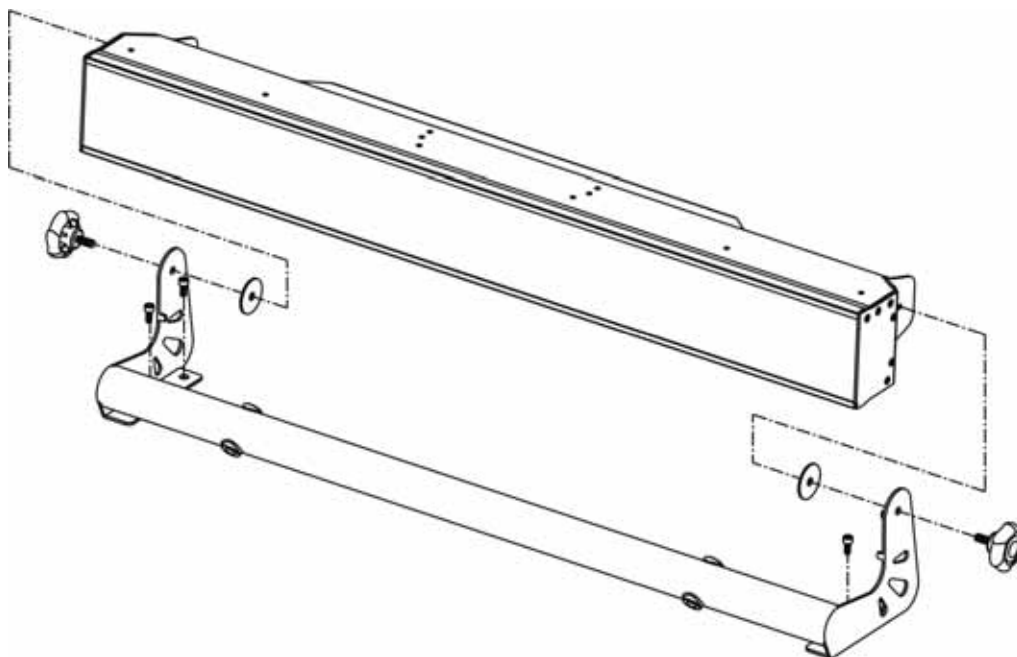

Operation

The control panel is located at the back of Tracpod 84, allows setting DMX address, calling auto-chase, and setting fixtures personality.

Using the Control Panel:

- [MODE] Browse through main menu or esc from current view.
- [SELECT] Browse through sub-menu.
- [UP] [DOWN] Make adjustment or activate function.

3.1 Control menu map

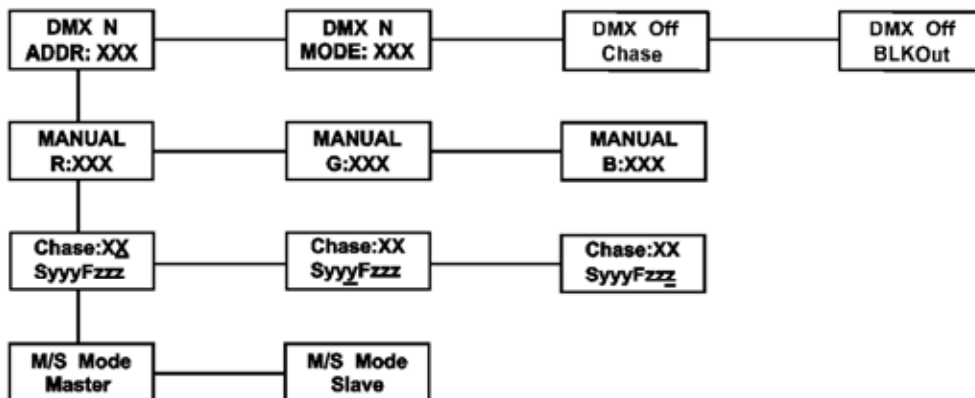

3.2 DMX Operation

i. Addressing the Fixture

1. Press [MODE] button to find DMX N
ADDR: XXX.
2. Use [UP] [DOWN] button to select desire DMX address from DMX N
ADDR: 001 – DMX N
ADDR: 512.

ii. DMX Protocols (Standard Function with 4 Channels)

Channel	Function	Value
Channel 1	Red	0-255
Channel 2	Green	0-255
Channel 3	Blue	0-255
Channel 4	Dimmer	0-159
	Strobe	160-255

iii. **DMX Protocols (Full Function with 7 Channels)**

Channel	Function	Value
Channel 1	Red	0-255
Channel 2	Green	0-255
Channel 3	Blue	0-255
Channel 4	Dimmer/ Strobe	0-255
Channel 5	Chase 1	0-15
	Chase 2	16-31
	Chase 3	32-47
	Chase 4	48-63
	Chase 5	64-79
	Chase 6	80-95
	Chase 7	96-111
	Chase 8	112-127
	Chase 9	128-143
	Chase 10	144-159
	Chase 11	160-175
	Chase 12	176-191
	Chase 13	192-207
	Chase 14	208-223
	Chase 15	224-239
	Chase 16	240-255
Channel 6	Speed	0-255
Channel 7	Fade Time	0-255

iv. **Setting the DMX Control Channel**

There are total of 40 LED cells on Tracpod 84 light fixture. The LED cells can be set to control as 1, 2, 5, 10, or 40 cells. Total of 6 DMX control channel modes are available.

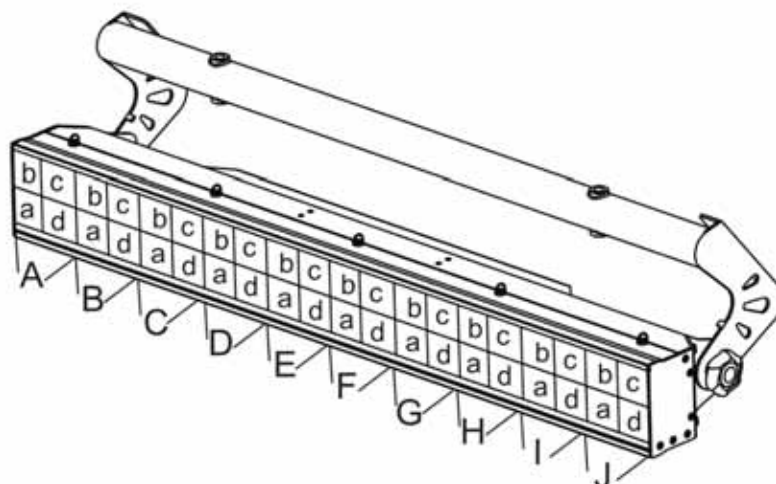

1. Press [MODE] button to find DMX N
MODE:XXX
2. Use [UP] [DOWN] button to select from 1 out of 6 available DMX control channel mode.

Mode	No. of LED Cell	Standard/Full Function
DMX N MODE:004	1	Standard
DMX N MODE:007	1	Full
DMX N MODE:008	2	Standard
DMX N MODE:020	5	Standard
DMX N MODE:040	10	Standard
DMX N MODE:160	40	Standard

v. DMX Signal-Off Setting

This setting use to set the unit to run chase or complete black out during course of DMX signal lost.

IMPORTANT

When unit is set to black out all stand-alone function output will be disabled except controlling the fixture using DMX signal.

1. Press [SELECT] to find submenu DMX Off
Chase .
2. Press [UP] [DOWN] button to select DMX Off
Chase or DMX Off
BLKOut .

3.3 Stand – Alone Operation

i. Using Master/Slave Mode

When making synchronous operation for multiple fixtures requires that they be connected on a

data link and one for the fixture set as master unit and rest set as slave unit. Only one fixture can be set as master unit and rest of salve unit mimic behavior of master.

IMPORTANT

Before using Master/Slave mode, fixtures must be disconnected from DMX controller. Data collision may occur if not disconnected.

1. Press [MODE] button to find M/S Mode
Slave menu.
2. Use [UP] [DOWN] button to set fixture as master M/S Mode
Master or slave M/S Mode
Slave unit.

ii. Manual Color Mixing

Make color adjustment manually using this mode. It provides intensity control for each red, green, blue colors.

1. Use [MODE] button to find Manual
R:XXX menu.
2. Press [SELECT] button to scroll through submenu and make adjustment using [UP] [DOWN] button.

RGB
R:000 – RGB
R:255 – Red saturation from value 000 – 255.

RGB
G:000 – RGB
G:255 – Green saturation from value 000 – 255.

RGB
B:000 – RGB
B:255 – Blue saturation from value 000 – 255.

iii. Auto Chase Mode

1. Press [MODE] button to find Chase:XX
SyyyFzzz menu.
2. Press [SELECT] button to scroll through Chase:XX
SyyyFzzz, Chase:XX
SyyyFzzz, Chase:XX
SyyyFzzz submenus.
3. Use [UP] [DOWN] button to set chase, speed, fade time.

Chase:01
SyyyFzzz – Chase:16
SyyyFzzz – Select chase from 01 – 16.

Chase:XX
S000Fzzz – Chase:XX
S255Fzzz – Set chase running speed from 000 – 255.

Chase:XX
SyyyF000 – Chase:XX
SyyyF100 – Set chase fade time from 000 – 100.

Technical Specification

Power

Input Voltage: AC100-240V 50-60HZ
Power Consumption: 120 W
Fuse: T2.0A

Light Source

LED: 840 RGB LED (280 Red,280 Green, 280 Blue)
Beam angle: 15°

Performance

2300 LUX @ 1M
1000 LUX @ 2M

Control and Programming

Protocol: USITT DMX 512
DMX Channels: 4, 7, 8, 20, 40, 160
Control Options: DMX, Master/Slave, Manual color mix, Auto-chase

Connections

Power: Neutrik Powercon
Data: 3 and 5-PIN XLR

Dimensions and Weight

Length: 1010 mm
Width: 258 mm
Height: 236 mm
Weight: 11.5 kg

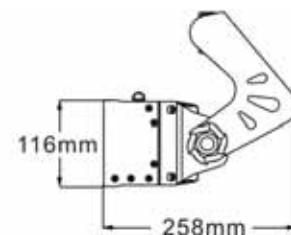
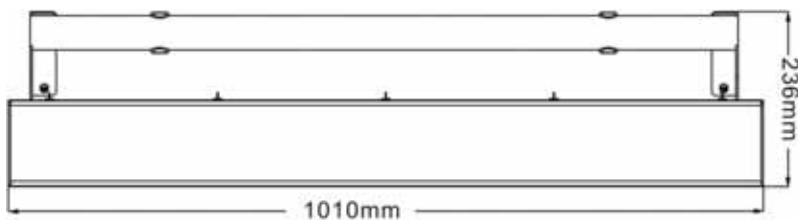

Maintenance

Keep the fixture dry and only install in well-ventilated areas.

Clean the fixture with a moist, lint-free cloth. Never use alcohol or solvents.

To maintaining adequate cooling, clean the dust from air vent regularly.

Fuse Replacement

1. Unplug mains before replacing fuse.
2. Unscrew the fuse holder using a flat head screwdriver (anti-clockwise).
3. Remove the damaged fuse from its holder and replace with exact same type fuse.
4. Insert the fuse holder back in its place then reconnect power.

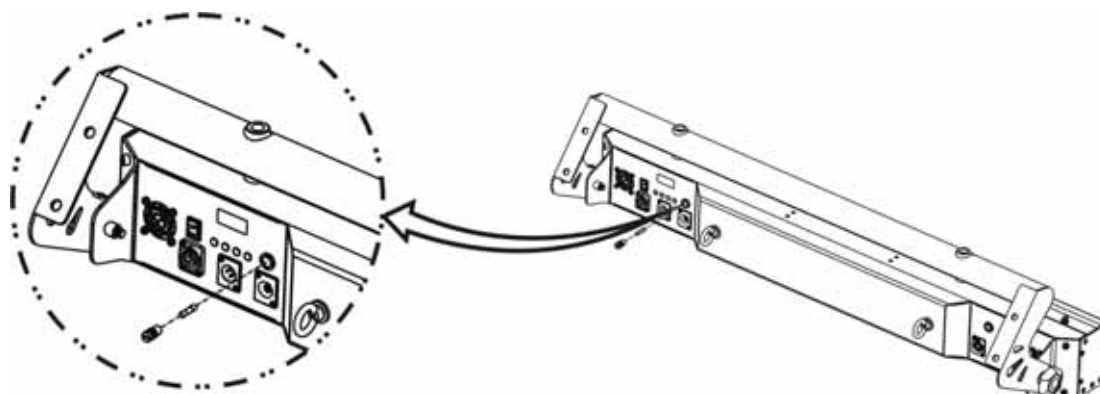



Alkalite LED Technology Corp.

Website: www.alkalite.com Email: info@alkalite.com