

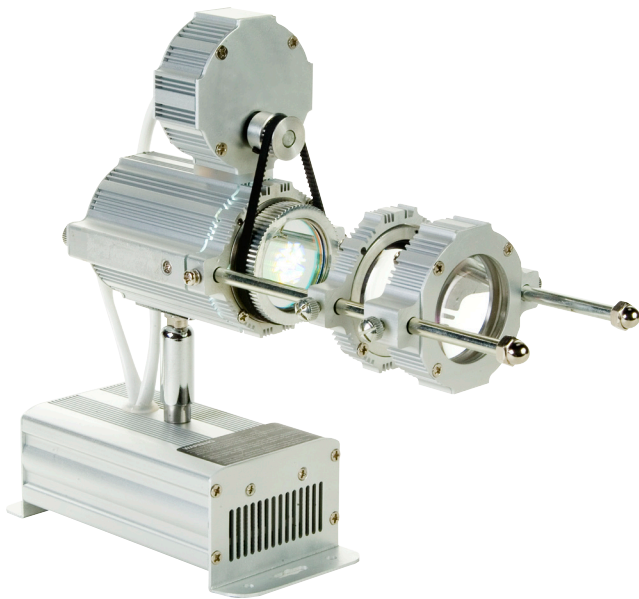

ELAR IPXR

www.elationlighting.com • www.elationlighting.eu



ELAR IPXR SPECIFICATIONS:

Lamp: 32W HID
 Working Position: Any safe working position
 Power Input Voltage: "Auto Sensing"
 120/230 VAC 50/60Hz
 Power Consumption: 37W
 Weight: 3.3lbs./ 1.5Kgs.
 Dimensions: 10.7" (L) x 3.74" (W) x 9.09" (H)
 273 x 95 x 231mm
 Warranty: 2 Year (730 days)

Gobo Replacement:

1. Remove the gobo retainer ring gobo frame.
2. Push the gobo out towards the front of the unit, and remove.
3. Insert your desired gobo and replace the retainer ring.

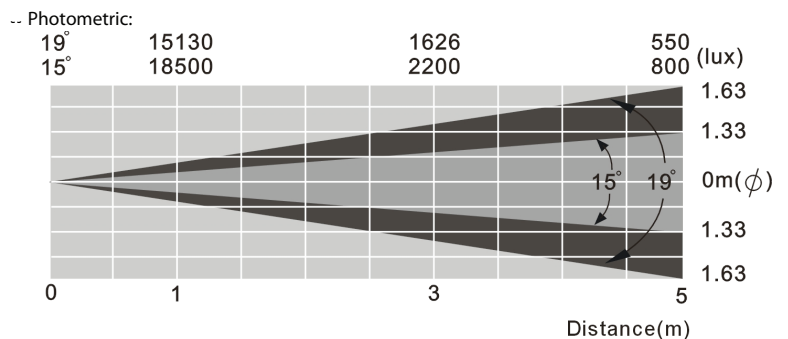

LAMP REPLACEMENT:

Remove the two phillips screws from the front lens, and then slowly remove the lens. Unscrew the lamp and replace with the exact same lamp.

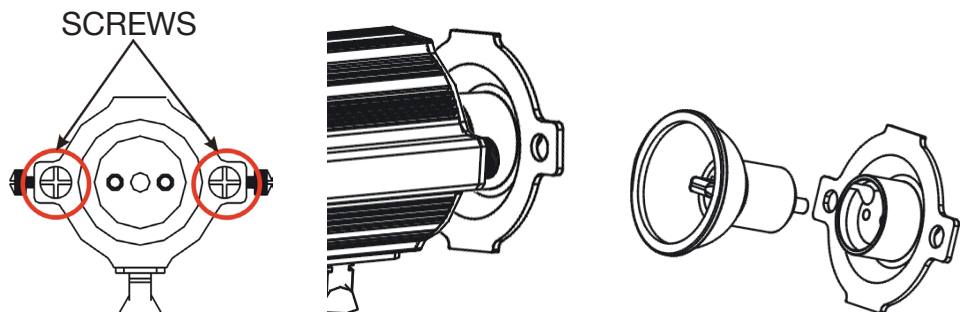

Caution! No user serviceable parts inside do not attempt repairs. In the event your Elation® Architectural fixture should fail, contact Elation® support.

Customer Support: Elation® provides a customer support line, to provide set up help and to answer any question should you encounter problems during your set up or initial operation. You may also visit us on the web at www.Elation®lighting.com for any comments or suggestions. Service Hours are Monday through Friday 9:00 a.m. to 5:00 p.m. Pacific Standard Time.

Voice: (323) 582-3322

Fax: (323) 832-9142

E-mail: support@Elationlighting.com

Elation® Architectural carries a 2 year (730 days) limited warranty. Please fill out the enclosed warranty card to validate your purchase. All returned service items whether under warranty or not, must be freight pre-paid and accompany a return authorization (R.A.) number. If the remote is under warranty you must provide a copy of your proof of purchase invoice. Please contact American DJ® customer support for a R.A. number.

2-YEAR LIMITED WARRANTY

A. Elation® Architectural hereby warrants, to the original purchaser, Elation® Professionals® products to be free of manufacturing defects in material and workmanship for a period of two years (730 days) from the date of purchase. This warranty shall be valid only if the product is purchased within the United States of America, including possessions and territories. It is the owner's responsibility to establish the date and place of purchase by acceptable evidence, at the time service is sought.

B. For warranty service, send the product only to the Elation® Professionals® factory. All shipping charges must be pre-paid. If the requested repairs or service (including parts replacement) are within the terms of this warranty, Elation® Professionals® will pay return shipping charges only to a designated point within the United States. If the entire instrument is sent, it must be shipped in its original package. No accessories should be shipped with the product. If any accessories are shipped with the product, Elation® Professionals® shall have no liability whatsoever for loss of or damage to any such accessories, nor for the safe return thereof.

C. This warranty is void if the serial number has been altered or removed; if the product is modified in any manner which Elation® Professionals® concludes, after inspection, affects the reliability of the product; if the product has been repaired or serviced by anyone other than the Elation® Professionals® factory unless prior written authorization was issued to purchaser by Elation® Professionals®; if the product is damaged because not properly maintained as set forth in the instruction manual.

D. This is not a service contract, and this warranty does not include maintenance, cleaning or periodic check-up. During the period specified above, Elation® Professionals® will replace defective parts at its expense, and will absorb all expenses for warranty service and repair labor by reason of defects in material or workmanship. The sole responsibility of Elation® Professionals® under this warranty shall be limited to the repair of the product, or replacement thereof, including parts, at the sole discretion of Elation® Professionals®. All products covered by this warranty were manufactured after January 1, 1990, and bear identifying marks to that effect.

E. Elation® Professionals® reserves the right to make changes in design and/or improvements upon its products without any obligation to include these changes in any products theretofore manufactured.

F. No warranty, whether expressed or implied, is given or made with respect to any accessory supplied with products described above. Except to the extent prohibited by applicable law, all implied warranties made by Elation® Professionals® in connection with this product, including warranties of merchantability or fitness, are limited in duration to the warranty period set forth above. And no warranties, whether expressed or implied, including warranties of merchantability or fitness, shall apply to this product after said period has expired. The consumer's and or Dealer's sole remedy shall be such repair or replacement as is expressly provided above; and under no circumstances shall Elation® Professionals® be liable for any loss or damage, direct or consequential, arising out of the use of, or inability to use, this product.

G. This warranty is the only written warranty applicable to Elation® Professionals® Products and supersedes all prior warranties and written descriptions of warranty terms and conditions heretofore published.